

## XC-3632-B – 5MP 3in1 IR Weatherproof Camera



**5MP AHD/TVI/Analog**

**UTC**

**20m IR**

**300m by RG6**

**IP66**

**DWDR**

### Features

- 5MP Megapixel CMOS Sensor
- Video output selectable :
  - 5MP AHD/TVI @20fps**
  - 4MP/1080p AHD/TVI @25fps**
  - 700TVL Analog @25fps**
- 3.6mm Fixed Lens
- IR LED, 0 Lux up to 20m
- 3D-DNR, DWDR, DSS, HLM
- TDN (True Day & Night)
- **UTC** OSD control
- English / Chinese OSD menu
- **Aluminum Casing, IP66**
- Suitable for Wall / Ceiling Mount

### DIMENSION

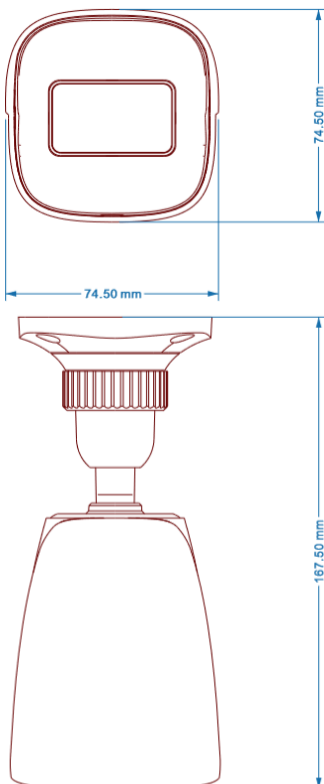

### SPECIFICATION

Model	XC-3632-B
Image Sensor	1/2.9" 5MP CMOS Sensor
Resolution	2560 x 1936 Pixels
Shuttle	1/25s ~ 1/100,000s
Lens	M12 3.6mm Fixed Lens
Video Output	5MP@20fps AHD/TVI or Analog
Day & Night	Filter Change or True Day&Night (TDN)
Min. Illumination	0 Lux up to 20m
LEDs	2nos 850nm IR LED ARRAYS
S/N Ratio	>52 DB
Casing	Aluminum with Epoxy Powder Coating
W. Environment	-10° ~ +55°C, Non-Condensing
Power	12VDC, Max. 400mA
Dimension (mm)	74.5 x 74.5 x 167.5mm(L), 0.39kg